

PATTERN DETAIL MEASUREMENTS

NOTE: measurements are approximate and will vary with register size.

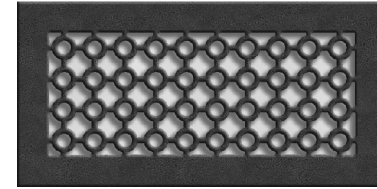
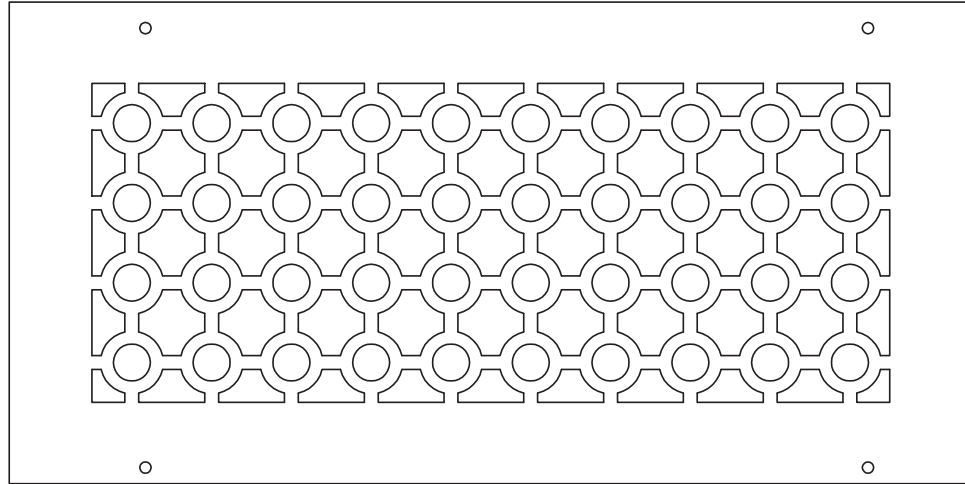
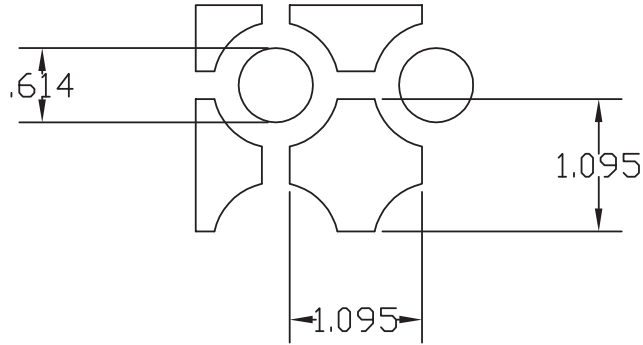

CASTLE DESIGN AIR FLOW / PERFORMANCE DATA

	250	500	750	1000	1500
Velocity					
Static Pressure	0.015	0.03	0.046	0.061	0.093
SIZE	CUBIC FEET PER MINUTE (CFM)				
6x6 (.25ft ²)	40	80	120	160	235
8x8 (.44ft ²)	70	140	210	280	425
10x10 (.69ft ²)	110	220	330	440	660
12x12 (1.0ft ²)	160	320	475	635	955
14x14 (1.36ft ²)	216	431	647	862	1294
8x6 (.33ft ²)	53	106	158	211	317
10x6 (.42ft ²)	66	132	198	264	396
12x6 (.5ft ²)	79	158	238	317	475
14x6 (.58ft ²)	92	185	277	370	554
16x6 (.67ft ²)	106	211	317	422	634
18x6 (.75ft ²)	119	238	356	475	713
20x6 (.83ft ²)	132	264	396	528	792
10x8 (.56ft ²)	88	176	264	352	528
12x8 (.67ft ²)	106	211	317	422	634
14x8 (.78ft ²)	123	246	370	493	739
8x4 (.22ft ²)	35	70	106	141	211
10x4 (.28ft ²)	44	88	132	176	264
12x4 (.33ft ²)	53	106	158	211	317



MATERIAL: 11 GAUGE STEEL
 ABOVE DIMENSIONS ARE IN INCHES
 FINISH: TO BE DETERMINED
 OVERALL OPENNESS, CASTLE PATTERN, 65%
 PROJECT:

SCALE	NONE
DRAWN	DL
DATE	10-18-06
Q.A.	
COMMENTS	

CASTLE DESIGN

THIS INFORMATION CONTAINED IN THIS DRAWING IS THE SOLE PROPERTY OF STEELCREST CORPORATION. ANY REPRODUCTION IN PART OR AS A WHOLE WITHOUT WRITTEN PERMISSION OF STEELCREST CORPORATION IS PROHIBITED

Castle ~ Submittal Sample